



Peelers Vegetable Peeler, 25 kg - Abrasive Plate

ITEM # _____

MODEL # _____

NAME # _____

SIS # _____

AIA # _____



603649 (DT25EF350)

25 kg vegetable peeler. Stainless steel body with abrasive plate and abrasive cylinder. Suitable for 100 to 500 meals

603650 (DT25EF150)

* NOT TRANSLATED *

Short Form Specification

Item No. _____

Constructed in stainless steel. The removable rotating plate and the cylinder are covered with a removable rotating plate covered in very resistant abrasive material (silicon carbide). Fully opening polycarbonate lid. An interlocking safety magnetic device will stop the machine when the unloading door is opened. Flat and waterproof touch button control panel with timer. The electronic controls and motor have IP55 protection. Supplied with abrasive plate and abrasive cylinder for hard vegetables peeling.

Main Features

- Suitable for 100-500 meals per service.
- Removable rotating plate covered in very resistant abrasive material (silicon carbide).
- Peels are reduced to small pieces to facilitate drainage process.
- Supplied with:
 - abrasive plate and abrasive cylinder as standard
- Timer with countdown display.
- Pulse function to control the unloading operation.
- Safety device stops the machine from operating with unloading door open.

Construction

- Complete stainless steel construction.
- IP55 waterproof touch button control panel.
- Transparent BPA free cover.

Included Accessories

- 1 of ABRASIVE PLATE FOR 25KG VEGETABLE PEELER PNC 653506

Optional Accessories

- MOBILE TROLLEY+FILTER TRAY-25KG PEELER (only for 603649) PNC 653302
- ABRASIVE PLATE FOR 25KG VEGETABLE PEELER (only for 603649) PNC 653506
- WASTE DILUTION UNIT FOR 25KG VEG. PEELER (only for 603649) PNC 653509

APPROVAL: _____



Peelers Vegetable Peeler, 25 kg - Abrasive Plate

Front

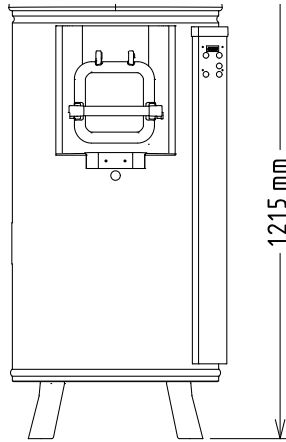

Side

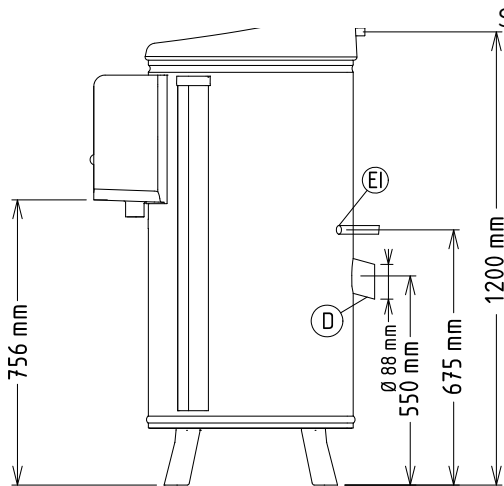

CWII = Cold Water inlet 1

D = Drain

EI = Electrical inlet
(power)

Top

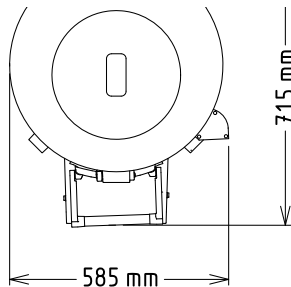

Electric

Supply voltage:

603649 (DT25EF350)

220-240/380-415 V/3 ph/50 Hz

603650 (DT25EF150)

220-240 V/1N ph/50 Hz

Electrical power max.:

603649 (DT25EF350)

0.9 kW

603650 (DT25EF150)

1.1 kW

Total Watts:

603649 (DT25EF350)

0.9 kW

603650 (DT25EF150)

1.1 kW

Capacity:

Performance (up to):

400 kg/Cycle

Capacity:

25 litres

Key Information:

**External dimensions,
Width:**

585 mm

**External dimensions,
Depth:**

785 mm

**External dimensions,
Height:**

1215 mm

Shipping weight:

603649 (DT25EF350)

90 kg

603650 (DT25EF150)

103 kg



Peelers
Vegetable Peeler, 25 kg - Abrasive Plate
The company reserves the right to make modifications to the products
without prior notice. All information correct at time of printing.

2026.04.21